

# EX SERIES

97  
%  
THERMAL EFFICIENCY

TOUCHSCREEN  
V-10  
PORTAL  
CONTROL ON THE GO

10:1  
TURNDOWN RATIO

BUILT-IN  
4  
ZONE  
PUMP CONTROL

24  
NETWORK UP TO 24x

# COMMERCIAL

HIGH EFFICIENCY  
CONDENSING BOILER

10  
YEAR  
HEAT EXCHANGER  
WARRANTY

2  
YEAR  
PARTS  
WARRANTY

MADE IN  
CANADA

IBC INTERGAS®

# EX SERIES

## Technical Information



SPECIFICATIONS	EX 700	EX 850
CSA Input (Natural Gas or Propane) - MBH	70 - 700	85 - 850
CSA Input (Natural Gas or Propane) - kW	20.5 - 205	24.9 - 249
CSA Output (Natural Gas or Propane) - MBH	679	824.50
CSA Output (Natural Gas or Propane) - kW	199	241.60
Thermal Efficiency	97%	97%
Min Gas Supply Pressure (Nat. Gas or Propane) - inch w.c.	4	4
Max Gas Supply Pressure (Nat. Gas or Propane) - inch w.c.	14	14
Ambient Temperature - Low	32°F / 0°C	32°F / 0°C
Ambient Temperature - High	122°F / 50°C	122°F / 50°C
Max relative humidity (non-condensing)	90%	90%
Min water Temperature	34°F / 1°C	34°F / 1°C
Max water Temperature - (electronic high limit)	190°F / 88°C	190°F / 88°C
Max. ΔT - supply/return (electronic fence)	80°F / 44°C	80°F / 44°C
Max. Water Temperature Lockout Limit	201°F / 94°C	201°F / 94°C
Power (120Vac/60Hz) @ full fire - watts (without pumps)	2.5	2.5
Weight (empty) - lbs/Kg	440 / 200	520 / 236
Heating Surface Area ft <sup>2</sup> / m <sup>2</sup>	84.6 / 7.86	99.88 / 9.28
Pressure Vessel water content - USG/Liters	17.5	17.5
Max boiler flow rate - USgpm	100	100
Min boiler flow rate to activate DHW heating - USgpm	18	21
Max Operating Water Pressure - psig	160	160
Min Operating Water Pressure - psig	8	8
Relief valve pressure - psig	50	50
Approved installation altitude	12,000 ft	12,000 ft
Max equivalent vent length (each side)	120'	120'

### PIPING CONNECTIONS

Flue Outlet	6" Schedule 40
Combustion Air Inlet	4" Schedule 40
Water Outlet	2 1/2" Male NPT
Water Inlet	2 1/2" Male NPT
Knockouts (8)	1/2"
Gas inlet	1" NPT-F
Condensate Outlet	3/4" Hose



### V-10 PORTAL

A secure method of remotely managing your EX Series Boiler from any location.

**Boiler control on the go!**

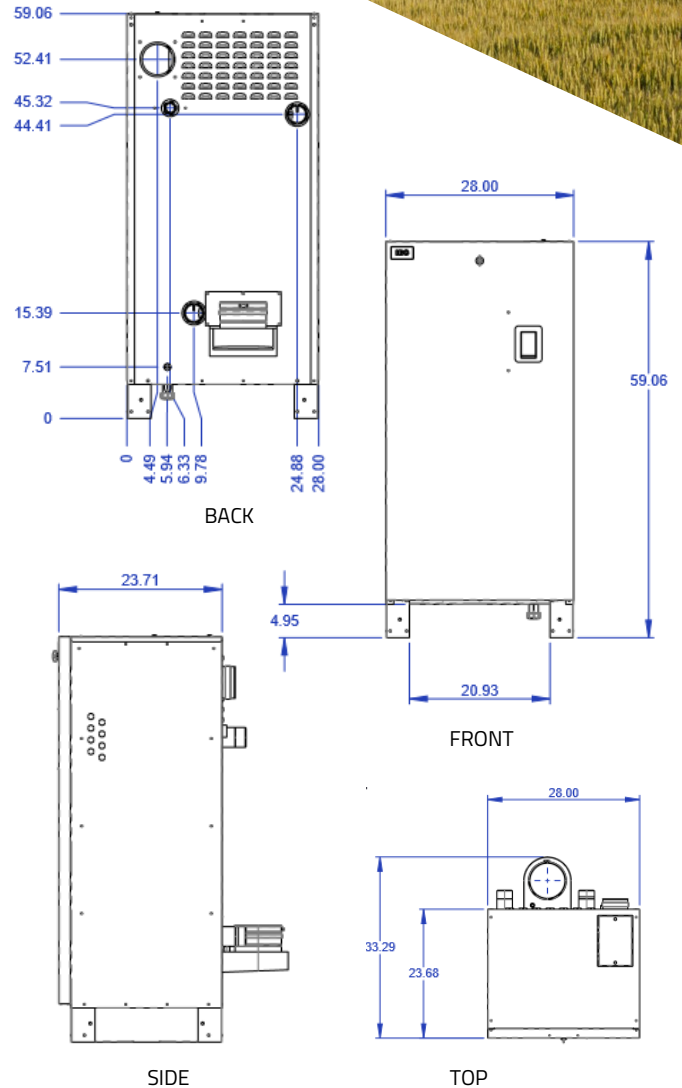

IBC Technologies  
sales@ibcboiler.com ▪ www.ibcboiler.com

**Toll Free: 1-844-HEAT IBC / 1-844-432-8422**

**IBC INTERGAS®**

All information contained in this brochure is subject to change without notice. Due to clerical error, regulation change or product development please confirm all information with IBC INTERGAS

900-330 (R3)